



Wall Mounted
AWK10N3H2

Contents

key features	3
technical requirements	4
what's inside	5
airflow	6
installation	7
clearance	8
additional connections	9
technical specifications	10
dimensions	13
wiring diagram	14
mounting template	16
warranty terms and conditions	17
nomenclature	19

KEY FEATURES

- **No outdoor unit**

The single package design means no outdoor unit, freeing up space on rooftops and at ground level and enabling installations in buildings without space for an outdoor unit.
- **BLDC twin rotary inverter compressor**

The state-of-the-art, twin rotary BLDC inverter compressor operates efficiently, quietly, and with minimal vibration. AIO is ideal for any room or area that requires between 4,000 and 10,500 BTU.
- **High-efficiency ECM fans with auto ESP**

High-efficiency ECM fans enable efficient and quiet operation as the EC motor can ramp up or down depending on the need. Automatically adjusted external static pressure ensures correct airflow.
- **Cold climate heat pump**

The heat pump operates efficiently down to 5°F outdoor temperature.
- **Optional ERV Module**

The optional ERV module enables make up/fresh air in the most efficient method possible.
- **Optional 1,800 Watt electric heat**

The optional electric heating system operates alongside the heat pump when the latter lacks adequate power. This electric heating setup consists of two 900W heaters, strategically staged to optimize efficiency while minimizing the consumption of electric heat. The unit offers configuration options for electric heat usage: it can be set to use no electric heat, 900W electric heat, or 1,800W electric heat, providing flexibility and energy management capabilities.
- **Intelligent defrosting**

AIO's intelligent defrosting system means more time heating and less time on reverse cycle defrost.
- **Coil cooling system**

The condensate mister system drizzles the condensate on the outdoor heat exchanger coils, lowering the coil's temperature and increasing efficiency and performance.
- **Quiet**

With whisper-quiet operation as low as 27 decibels, the occupant will barely notice AIO is operating.
- **No outside noise infiltration**

AIO has the lowest STC and OITC rating among comparable units. This means less outside noise intruding into the room day and night
- **Versatile on/off options**

AIO's low voltage connection enables connection to any occupancy system, key-card, window sensors, fire alarms, etc.; as long as it can send a signal to AIO via low voltage, the unit can be easily turned on or off.
- **Corrosion protection**

AIO comes standard with corrosion protection, assuring many years of trouble-free performance.
- **Minimal clearances and compact footprint**

AIO's compact form with no line sets means there is no need to access the sides of the unit. Mount units with as little as 3/4 inch clearance on all sides. Compact footprints take up minimum space.
- **Leak protection**

A drain alarm will activate if the drain becomes clogged, and the system will be shut off, preventing water damage.
- **Easy to service**

AIO can be easily maintained and repaired from the front or bottom of the unit without having to remove the unit from the wall or ceiling. AIO can also be quickly swapped out with a replacement, reducing downtime.
- **Versatile controls**

AIO includes an onboard touch controller and an optional iOS and android app. AIO can be used with optional wall-mounted controllers, including a touch screen 7-day programmable and third-party controllers from any company using the optional 3rd party kit. An optional BACnet and Modbus module enables interfacing with building management systems
- **10-Year limited warranty**

An industry-leading ten-year limited warranty provides peace of mind. Comprehensive on-site one-year parts and labor. Nine-year parts warranty on the compressor.

Available extended on-site comprehensive parts and labor warranty for five, ten and 15 years..

TECHNICAL REQUIREMENTS

Site Requirements

Note: Refer to the full specifications for detailed information about the list of specifications.

- The power supply circuit is installed in accordance with the current edition of NEC (ANSI/NFPA 70) and local codes and ordinances. Note: Always consult local and national electric codes.
- Voltage rating of 60 Hz, single phase in 115V or 208/230V in accordance with the model specified
- Interior clearances as follows:
 - Sides of unit to wall: 1"
 - Bottom of unit to floor 1"
 - Top of unit to any obstruction: 3.5"
- Unblocked vents on the exterior and no obstacles within 36".
- An internal drain is highly recommended.
- If using an externally run condensate line, note the following:
 - Must be properly insulated
 - Minimum of 30% slope
 - If on a low floor, ensure that end of drain is above the

maximum height of snow buildup.

- Highly recommended to use a heat trace wire on the drain line to prevent freezing. This can be connected to the a heat trace power connection on the bottom of the unit.
- Approved louvers installed with best practices to ensure no water into the wall assembly.
- 8" diameter ducts through the wall which protrude 1/8" into the unit's EPDM backing to ensure a tight seal.
- The unit must be perfectly level on the vertical and horizontal axis.
- The unit must be tight to the wall, with zero leakage between the external ducts and the unit. Use insulating material if wall is not level.
- Properly affixed wall bracket to wall studs or other supporting material. Note the wall bracket has several places that must be secured.

Louver Specifications

AIO Wall Mounted Pro units can be vented through all kinds of custom and creative solutions. The possibilities are endless, from perforated panels to custom louvers.

There are two critical factors in selecting and sizing a solution that will work with AIO Wall Mounted Pro units.

- **Free area:** This area on a louver/grille is open for the air to flow through. The louver, perforated panel, or other solution must have at least the amount of free area as required in the specifications below in the plenum from the unit so that ample air can enter and exit the condenser chamber. A more restrictive solution with a smaller free area can be utilized by enlarging the louver and plenum until the required free area is achieved.
- **The minimum free area required is 0.34 sq feet for the intake vent and 0.34 sq feet for the exhaust vent.**
- **Pressure drop:** Pressure drop is the resistance the louver/grille creates against the airflow. This resistance can create heat build-up inside the condenser portion, causing the compressor to overheat and shut down. A solution

drop is within specification.

The maximum total pressure for the intake and exhaust ducting (if any) and intake and exhaust louvers combined must be under 0.45" WC

To be clear, the entire assembly of ductwork, plenums, and louvers for the complete air circuit, in and out of the system may not exceed 0.45" WC.

- Any louver or louver or assembly must meet these requirements, as exceeding these limits can cause the unit to overheat and fail and void the warranty.
- The following louvers are approved for AIO Wall Mounted Pro:
 - Sunvent: LLA/C, LLA/M, LLA/S - available through your Ephoca distributor.
 - Therma duct: RLA9 - available through your Ephoca distributor.

WHAT'S INSIDE

- 1. Return air grille
- 2. Washable Filter
- 3. High-efficiency indoor heat exchanger
- 4. Tangential supply fan
- 5. Supply air louver
- 6. Wall Mount bracket
- 7. ECM Axial condenser fan
- 8. Accessory connection ports
- 9. BLDC inverter compressor
- 10. Outdoor high efficiency heat exchanger

- 11. Condensate drain pan
- 12. Condensate pump
- 13. Insulation panel
- 14. Decorative cover panel
- 15. Condensate disbursement system
- 16. Touchscreen controller
- 17. Outside air intake

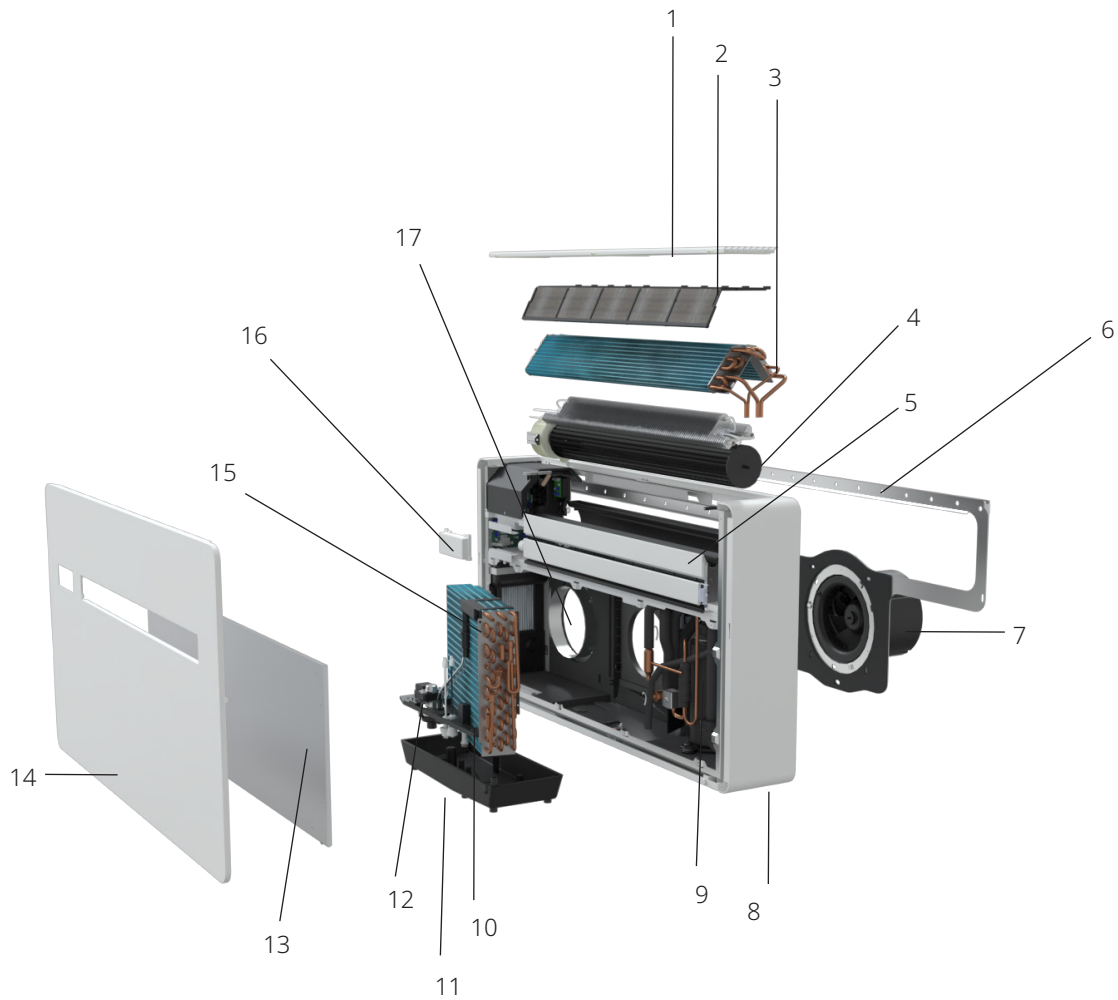

AIRFLOW

AIO Wall Mounted Pro is extraordinarily flexible in how it can externally vent. A host of adapters are available that enable AIO Wall Mounted Pro to be installed in many scenarios, including on glass curtain walls with linear louvers, integrated window, and louver assemblies, or even with no construction using a windowsill adapter.

- **Supply air**
The supply air is through an electronically controlled louver that can be set at any angle or continuously oscillate.
- **Return air**
The return air is on the top through the integrated return air grille.
- **Outside air intake**
The 8-inch round outside air intake connection can be ducted or used with an adapter with up to 0.45-inch external static pressure (combined between intake and exhaust). Use with any of the approved or custom louvers/ as long as they comply with the minimum requirements. See page 4.
- **Outside air exhaust**
The 8-inch round exhaust connection can be ducted or used with an adapter with up to 0.45-inch external static pressure (combined between intake and exhaust). Use with any of the approved or custom louvers/as long as they comply with the minimum requirements. See page 4.

1.	Room return air
2.	Supply air
3.	Outside air intake
4.	Exhaust air

■ Outside air ■ Recirculate air

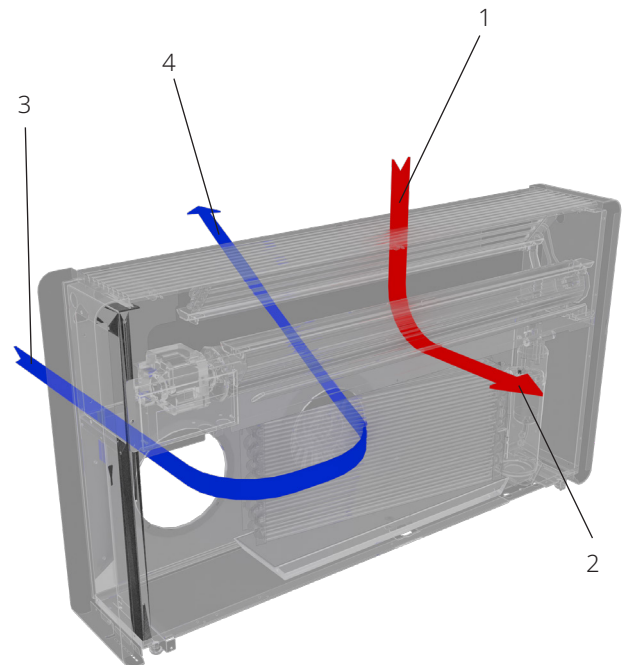

INSTALLATION



CLEARANCE

The AIO Wall mounted unit's clearance will depend on how it is mounted. Please carefully read the criteria below to determine the correct clearance required.

- Top - low wall mounted**
 There must be 3.5" minimum clearance to any surface above, such as a shelf, etc. This is needed for the return airflow. 8" of clearance is recommended for ease in changing the filter and servicing the unit.
- Top - high wall mounted**
 There must be 3.5" minimum clearance from the ceiling. This is needed for the return airflow. 8" of clearance is recommended for ease in changing the filter and servicing the unit.
- Bottom**
 There must be a minimum of 1" from the floor to eliminate any noise from vibration. 2" of clearance is ideal to allow the floor under the unit to be cleaned.
- Sides**
 The AIO Wall mounted unit should not touch the wall on either side as it will vibrate slightly during operation, which may create noise. As little as 3/4" clearance will suffice to eliminate any noise from vibration. A clearance of 2.5" on the sides allows for easier access when removing and installing the unit.
- Front**
 Ensure no curtains, furniture, plants, or any material is within 30" in front of the unit. The supply air vent is on the front, and blocking it will inhibit the airflow and the unit from working correctly.
- Rear**
 The rear of the unit must be tight to the wall so there are zero gaps between the wall and the unit. Gaps can allow outside air inside and create short cycling and humidity. If there are any gaps, they must be sealed with insulation.
- Exterior**
 On the exterior of the building, there should be no obstacles blocking the airflow from the louver. There must be a least 36" of free and clear space in front of the louvers.

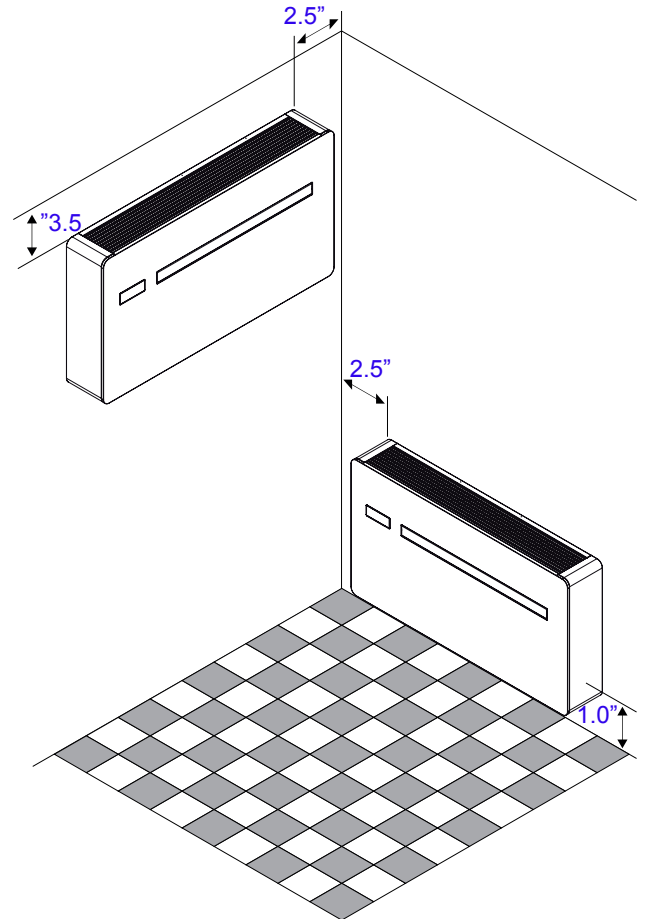

ADDITIONAL CONNECTIONS

AIO Wall Mounted Pro offers a group of connections on the bottom of the unit to enable quick and easy connection to accessories and components. This includes the following:

Controller Gateways

This includes power and communication ports to connect the Third Party Gateway, Advanced Touch Controller, Basic Touch Controller, BACnet, Modbus and other controllers.

Heat Trace Power

When installing a condensate line that is draining directly outside, in cold climates, we highly recommend using a heat trace line.

ERV

When connecting the AIO ERV these ports allow quick connections to the power and communications for the ERV.

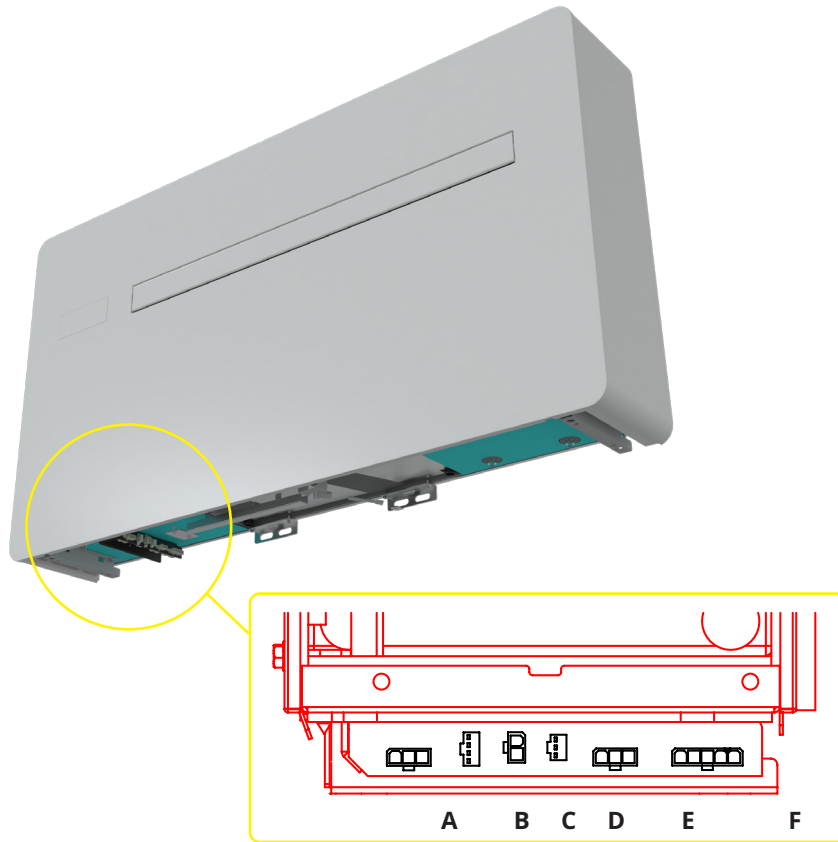

A - Power Supply for Controller Gateway

B - Communication port for Controller Gateway

D - Communication port for ERV

E - Power for ERV

TECHNICAL SPECIFICATIONS

Cooling		95°F¹	105°F²	115°F³
Heat Pump				
Maximum		15,000	12,000	13,500
Nominal	Btu/h	9,000	8,200	7,700
Minimum		3,300	3,300	3,300
Input Power	W	801	909	982
Efficiency		15.74 SEER2	9.02 EER2	7.84 EER2
Moisture Removal	Pts/h	1.9	-	-

- 1 **95°F** Indoor: 80°F, W.B. 67°F; Outdoor: 95°F, W.B. 75°F
- 2 **105°F** Indoor: 80°F, W.B. 67°F; Outdoor: 105°F, W.B. 75°F
- 3 **115°F** Indoor: 80°F, W.B. 67°F; Outdoor: 115°F, W.B. 75°F

Heating		47°F⁴	17°F⁵	5°F⁶	0°F⁷	-5°F⁸
Heat Pump (+ Optional 3,000 /6,100 BTU/H elec heat)						
Maximum		14,500	9,100	6,700	6,500	6,100
Nominal	Btu/h	8,200	7,600	5,600	5,400	5,100
Minimum		3,300	3,300	3,300	3,300	3,300
Input	W	711	935	919	953	917
Efficiency		8.45 HSPF2	2.38 COP2	1.76 COP2	1.66 COP2	1.63 COP2

- 4 **47°F** Indoor: 70°F, W.B. 67°F; Outdoor: 47°F, W.B. 43°F
- 5 **17°F** Indoor: 70°F, W.B. 60°F; Outdoor: 17°F, W.B. 13°F
- 6 **5°F** Indoor: 70°F, W.B. 60°F; Outdoor: 5°F, W.B. 3°F
- 7 **0°F** Indoor: 70°F, W.B. 60°F; Outdoor: 0°F
- 8 **-5°F** Indoor: 70°F, W.B. 60°F; Outdoor: -5°F

Airflow

Fresh air volume

Indoor	Type	ECM centrifugal
	Supply connection	Integrated front
	Return connection	Integrated bottom
	Filter	MERV 3
Outdoor	Type	ECM centrifugal

General

Compressor

Refrigerant	Type	R32
Type	BLDC twin rotary inverter	

Modes

Timers	Dependent on controller
Restricted modes	Heat only, cool only, temperature limiting

Condensate

Pipe	Size	3/4" Outside diameter
	Material	Rubber

Sound

Sound

Indoor	STC	40
	OITC	35
Outdoor	dB(A)	28-55

Dimensions

Electrical

General	
Heating (max)	13.1
Volt range	180-253
Heating (nominal)	10.5
Cooling (max)	4.8
Cooling (nominal)	3.8
Input power (off mode)	1.5
Input power (standby)	10.8
Power factor (%)	0.96
Power supply	Hardwire or LCDI
Hz/phase	60 Hz single phase

Motors		
Compressor	RLA	2.8
	LRA	3.9
Indoor ECM fan motor	W (max)	50
	F.L.A.	0.2
	HP	0.07
Outdoor ECM fan motor	W (max)	90
	F.L.A.	0.4
	HP	0.12

Circuit breakers	
MOCB	25
Recommended breaker size	20
MCA	15

LCDI Power Cord	
Plug Type	6-20P
Amps	20

EXTERNAL FAN

The AIO Wall Mounted Pro uses an extraordinarily powerful fan that sits inside the sleeve / plenum box/ wall assembly. When installing the unit, first the mounting bracket is secured to the wall, then the fan is secured to the wall bracket and connected to the AIO wall Mounted unit

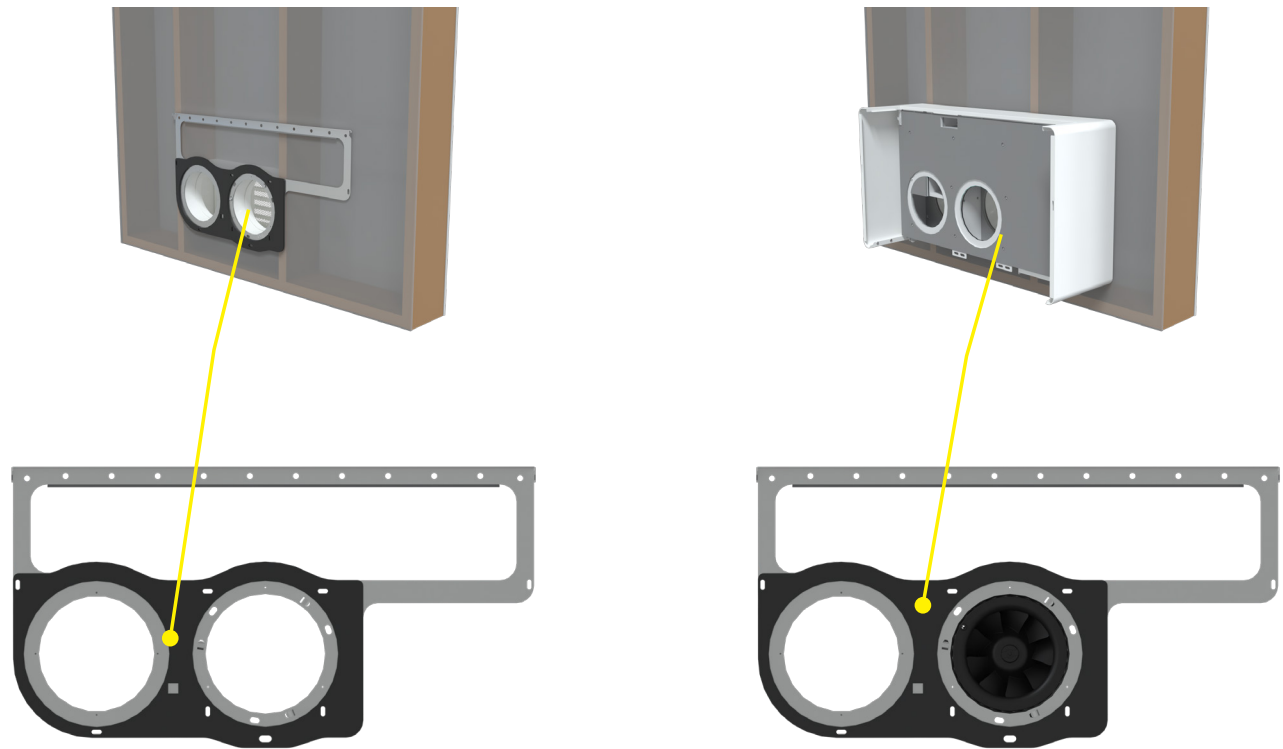
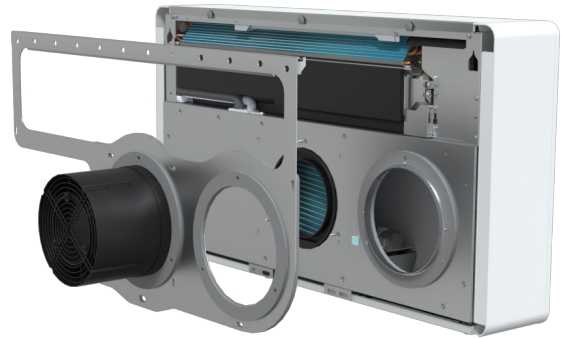

WIRING DIAGRAM

Heat Pump Only

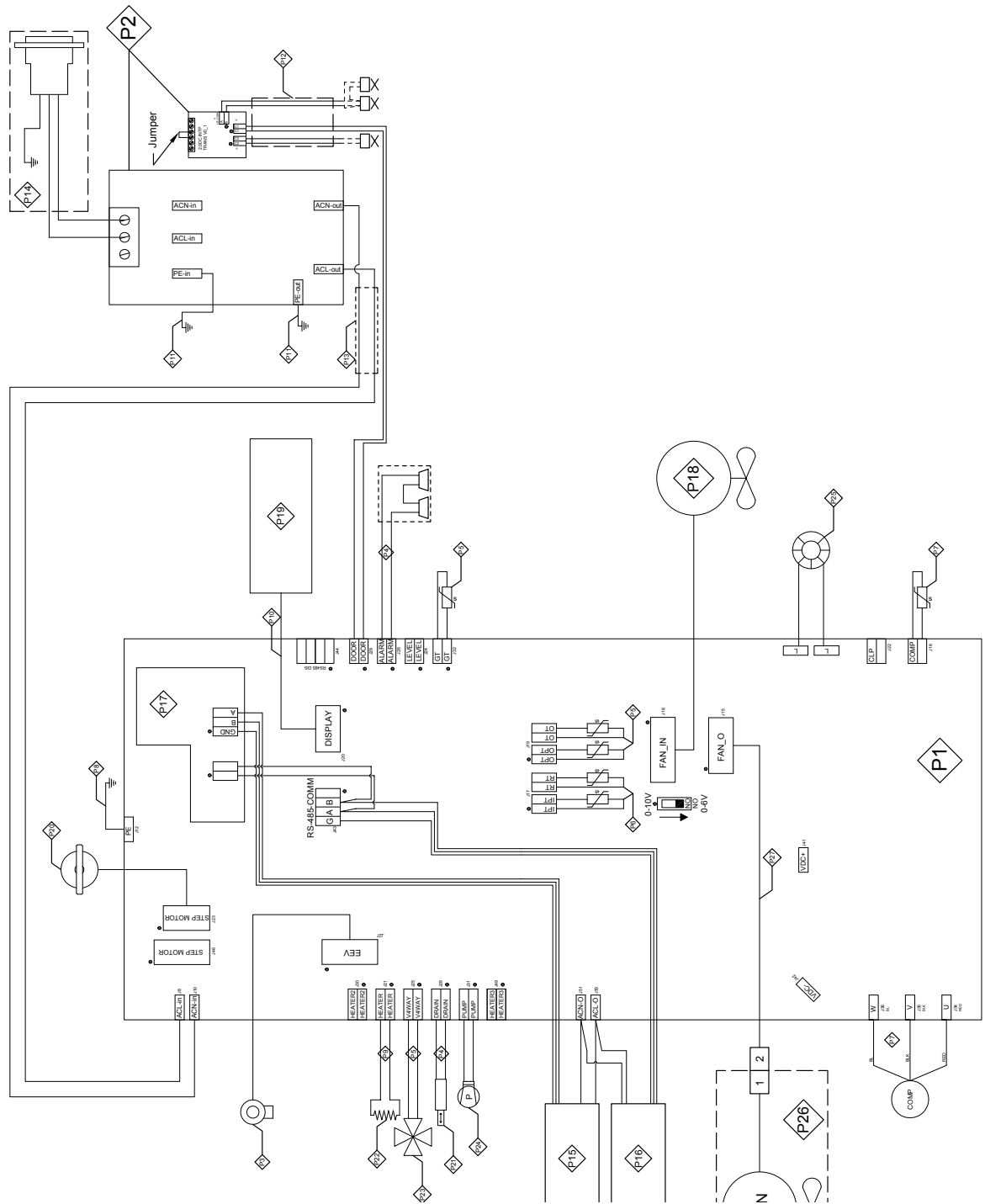

Heat Pump + Electric Heat

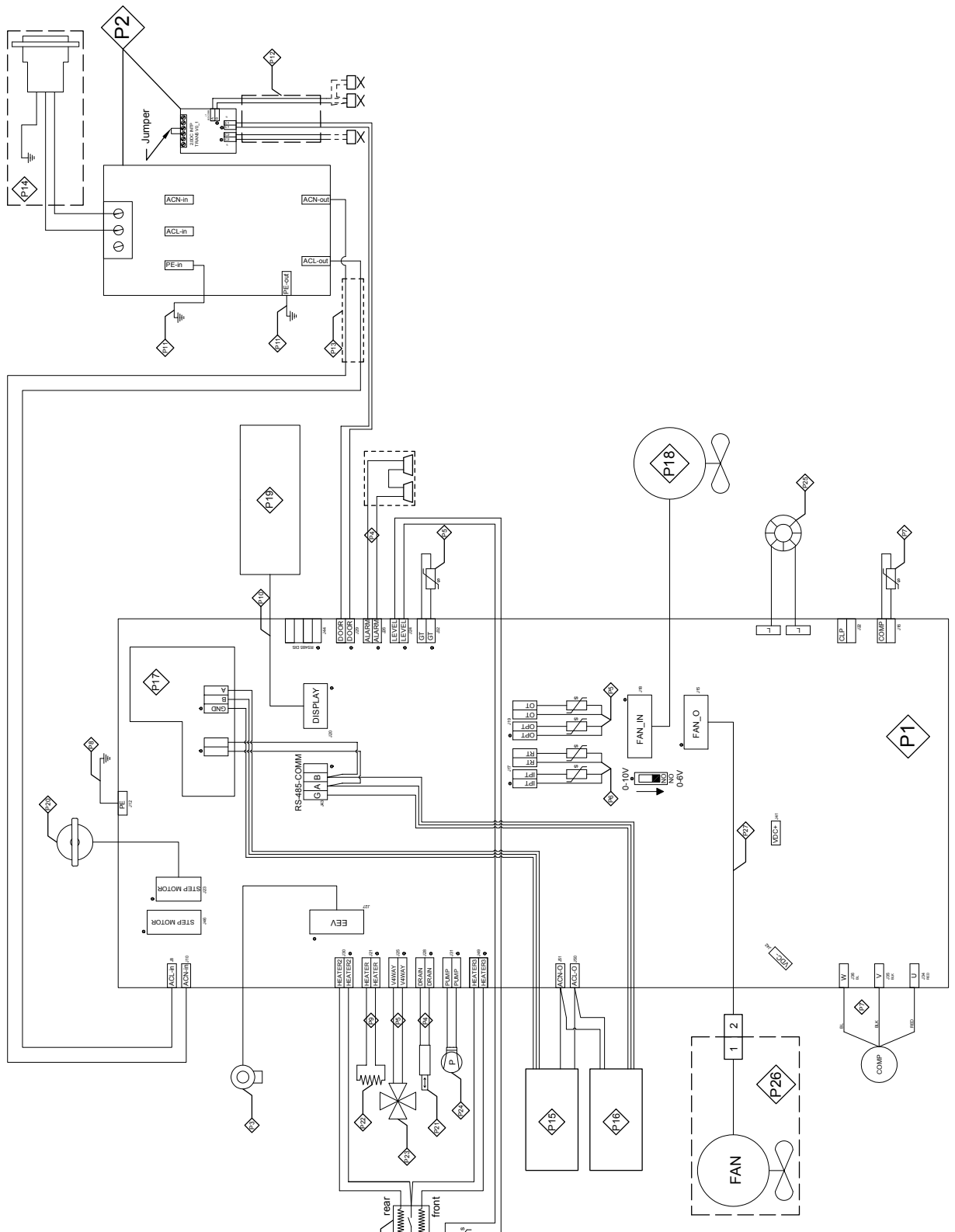

Notes

230V Electric Heat

PART	DESCRIPTION	EPHOCA CODE	Notes
P1	INTEGRATED PCB	N540205A	Included in N576205A
P2	FILTER 2.0 18A PCB	N560536A	Included in N576205A
P3	EEV COIL	N276928B	Included in N576205A
P4	Pan cables harness	N576205A_02	Included in N576205A
P5	4way valve cable+ temperature sensor	N576205A_03	Included in N576205A
P6	Indoor and Incoil temperature sensors	N576205A_04	Included in N576205A
P7	Compressor cables + discharge temperature sensor	N576205A_05	Included in N576205A
P8	PE IntPCB	N576205A_06	Included in N576205A
P9	Kit wiring heating elements	N576205A_07	Included in N576205A
P10	Display cable	N576205A_08	Included in N576205A
P11	PE filter wiring diagram	N576205A_09	Included in N576205A
P12	Transfer cables wiring diagram	N576205A_10	Included in N576205A
P13	Power supply to IntPCB	N576205A_11	Included in N576205A
P14	Power cable with USA 2.0 NC connector	N500399A	
P15	Power + RS485 cable for ERV 2.0NC	N500400A	
P16	2.0NC Rolbit power + communication cable	N500403A	
P17	WI-FI Expansion 2.0/WLH	N540217A	
P18	Internal Fan	N276300B	
P19	Display	N570177A	
P20	Flap motor	N276300B	
P21	DRAIN THERMO ACTUATOR	276417A	
P22	HEATING ELEMENT KIT	N560043B	230V version
P23	4 WAY VALVE	N276916A	230V version
P24	DRAIN PUMP	N640019A	230V version
P25	PFC Reactor	N579099A	230V version
P26	EXTERNAL MIXED FLOWN FAN	N520227A	
P27	EXTERNAL FAN cable from IntPCB to base	N500398A	
P28	TUBULAR HEATING ELEMENT 2x900w -230V	N560506A	
P29	187.25Kohm Copper probe L = 300mm	N500321A	

MOUNTING TEMPLATE

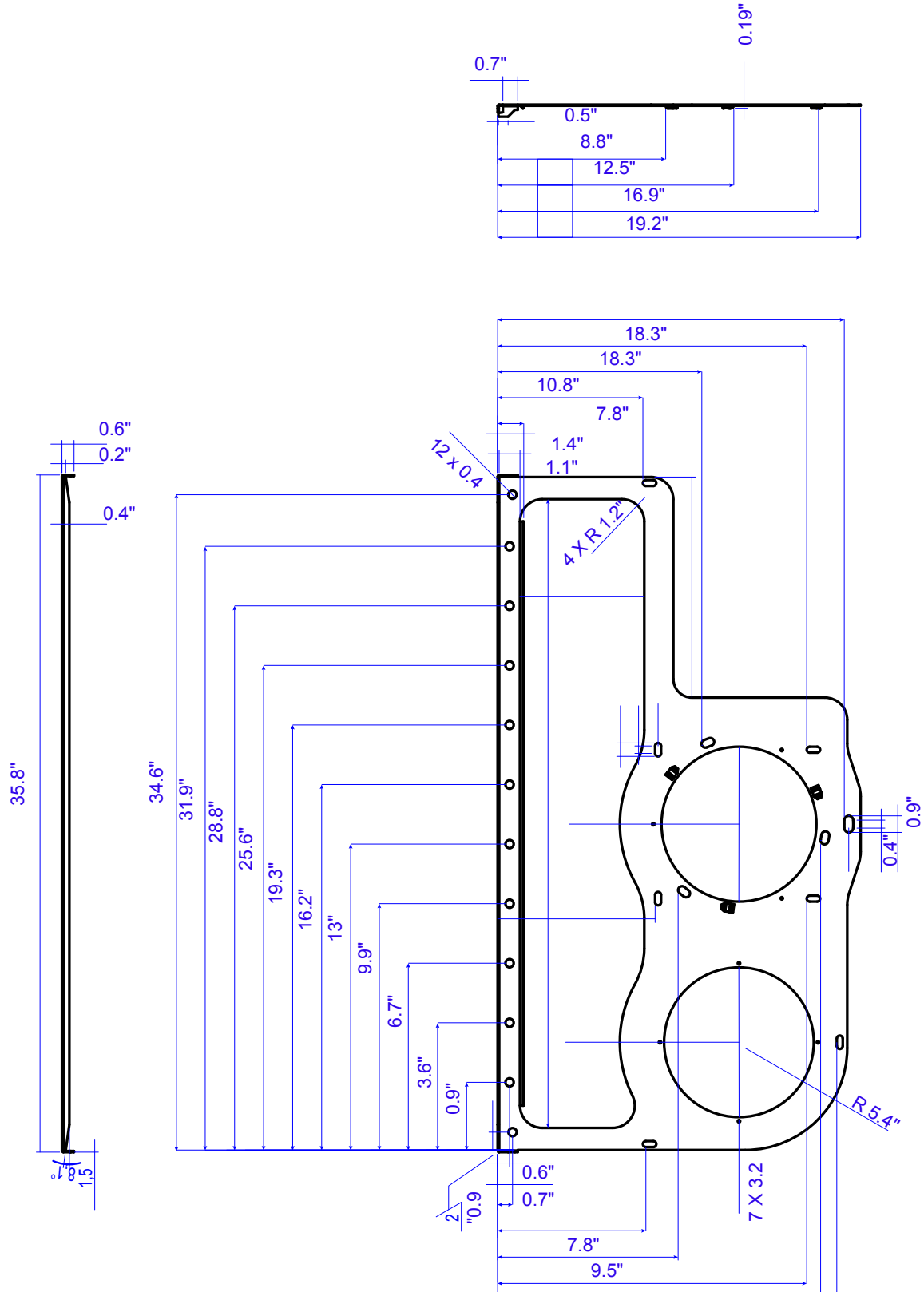

WARRANTY TERMS AND CONDITIONS

Ten Year Limited Warranty

This limited warranty is valid in the Continental United States only and only for the AIO series heat pump which was purchased and installed in its original installation location. This warranty is only valid when the AIO series heat pump air conditioner meets all the conditions below:

- Purchased from an Ephoca authorized distributor.
- Installed by an Ephoca certified technician.
- The installation was certified by an Ephoca technician before the AIO series heat pump was used.
- AIO is operated and maintained in accordance with the printed instructions in the user guide and in compliance with applicable local installation and building codes and good trade practices.
- The site must have a minimum of ten (10) units and there must be spare units on site equal to a minimum of three (3) units or 2.5% of installed units, whichever is greater.

These spare units must be used to replace a unit with a service issue until an Ephoca technician can be on site.

- A maintenance contract with a professional service provider must be in place to ensure the units are maintained and filters kept clean. You must submit documented filter cleaning every two months. You must submit documented annual unit cleaning.
- For any jobs sold with less than 10 units the distributor/ dealer is responsible for all labor costs and responsible for having attic stock for replacements.
- Every job must be inspected before turning on the units, and pictures of at least 10% of the units must be sent to our office. There are no exceptions. The warranty is not valid without a written letter from Ephoca after the installation pictures are reviewed per the self-certification process guide.

What This On-site Warranty Covers

Ephoca, Inc. ("Ephoca") warrants your AIO series heat pump air conditioner ("AIO") against failure due to defects in materials or workmanship under normal use, beginning on date

of certification by the Ephoca technician for the following periods:

Full One-Year Warranty

For the period of one year from the date of certification by the Ephoca technician, Ephoca will replace any part of the AIO which fails due to a defect in materials or workmanship. During this full one-year warranty, Ephoca will provide, on-site, free of charge, all labor and related service costs to

replace the defective part. If you are located in an area where we do not have Ephoca certified technician, we will ship you a replacement unit at our cost and arrange to pick up the defective unit at our cost.

Limited Ten-Year Warranty On Compressor

For the period of ten-years from the date of certification by the Ephoca technician, Ephoca will replace the compressor part should it fail due to a defect in materials or workman-

ship. During this limited ten-year compressor warranty, Ephoca will provide a replacement compressor, however, you will be responsible for all labor costs and related service costs.

Optional Extended Five, Ten and Fifteen Year Comprehensive Warranty

A comprehensive extended warranty is available for five, ten, and fifteen years from the date of certification by the Ephoca technician. During this extended warranty, Ephoca will replace any part of the AIO which fails due to a defect in materials or workmanship.

purchased directly from Ephoca within 90 days of installation. Controllers carry a two-year warranty; extended warranties exclude labor for wall controllers.

During this extended warranty period, Ephoca will provide, onsite, free of charge, all labor and related service costs to replace the defective part. If you are located in an area where we do not have Ephoca certified technicians, we will ship you a replacement unit at our cost and arrange to pick up



AIO WALL MOUNTED PRO -115V -900W ELECTRIC HEAT - R32 -SUBMITTAL (APE10N3H1)

Job	Reference	Construction
Location	Approval	Quote Number
Engineer	Date	Drawing Number
Submitted To	Submitted By:	P.O. Number:

General Features

- BLDC inverter compressor
- ECM fans
- R32 Refrigerant
- Intelligent defrost
- No outdoor unit
- Condensate disbursement systems
- Onboard touch controller
- Optional add-on ERV
- Washable filter
- Electronically controlled air louver
- Compact, slim design
- 3 selectable fan speeds + Auto
- 10 Year limited warranty includes 1 year parts and labor and Additional 9
- Made in Italy

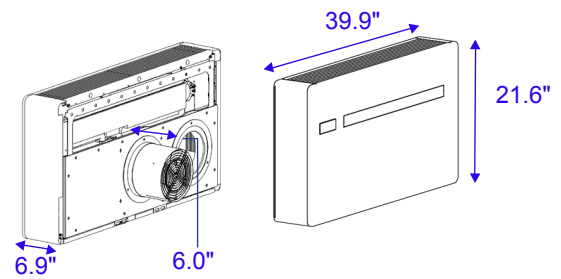

Performance Specifications

Cooling Capacity (Btu/h)	15,000
SEER2	15.74
EER2	11.23
Rev. Cycle Max Heating Capacity (Btu/h)	14,500
Electric heat (Btu/h)	3,070
Total Heat Capacity w/ Elec (Btu/h)	17,570
HSPF2	8.45
Circulation (CFM)	160-290
Dehumidification (Pts/h)	1.9

1. EER2 and SEER2 are based on nominal capacity of 8,900 Btu/h
 2. COP/ HSPF2 are based on nominal capacity of 8,200 Btu/h. COP/HSPF2 only take into consideration the heat pump and not electric heat

Electric Specifications

Electric Heat	
Power Supply (V Ph, Hz)	115 / 1 / 60
Voltage Range	103-127
Running Amps Cooling	6.9
Max Amps Cooling	14.7
Running Amps Heating	13.6
Max Amps Heating	22.0
MCA	30
Maximum Overcurrent Protection (A)	40
Recommend breaker size	30
Max Power Input (watts) Cooling	1,800
Max Power Input (watts) Heating	2,700

Wall Controllers + Gateways

<input type="checkbox"/> Wireless Remote	WRCH20
<input type="checkbox"/> Basic Touch Controller	LTCH20
<input type="checkbox"/> Recessed Touch Controller	RTCH20
<input type="checkbox"/> Advanced TFT Controller with 7-Day program	TFTH20
<input type="checkbox"/> Wireless (AA Battery) Infrared Controller with 7-Day program	WIPT20
<input type="checkbox"/> Third Party Gateway	TPG015
<input type="checkbox"/> Modbus	MODH20
<input type="checkbox"/> WiFi App	WIFI30
<input type="checkbox"/> E-Paper EOS Controller	EEOS12
<input type="checkbox"/> Simple EOS Controller	SEOS12
<input type="checkbox"/> BACnet	BACH20

General Accessories

<input type="checkbox"/> ERV	AWERV30
<input type="checkbox"/> Underbody Cover Plate	GB0737II
<input type="checkbox"/> Underbody Cover Plate for unit w/ERV	GB0737I4
<input type="checkbox"/> Reducer Plate from 8" to 6"	RED2016

LCDI Power Cords

Electric Heat	Whip	Plug	SKU
<input type="checkbox"/> + 900W	72 in.	NEMA 6-15P	L220v15a